

190 AUTOMATIC FEED GRINDER



A Great Team...The Hollymatic 190 Automatic Feed Grinder and The Hollymatic 180A Mixer/Grinder

For continuous heavy-duty production this tandem operation ties the 190 Grinder and 180A Mixer/Grinder together to move product through the first grind, mixing, and second grind production cycles. Lower Gemini System. (shown above) Upper or straight connection also available.



COMPACT...TOUGH...AND FAST!

The Hollymatic 190 Automatic Feed Grinder was designed for first grind coarse ground production of whole muscle product in supermarkets and meat plants. The 190 features a compact design, high strength/high torque augers and can take on and grind tempered meat and large fresh meat pieces with ease and speed.

- Special self-feeding augers clear the tub, reducing waste and making clean-up faster.
- 100 lb. tub capacity with optional extension feature increases capacity up to 200 lbs.

- Hardened gears, driven by a 7½ HP. motor develop high grinding torque.
- Enclosed drive and seal lubrication system for minimum maintenance.
- Interlock switch shuts off power when lid is opened or optional extension is raised.
- Stainless steel swing-open tub and no special tool disassembly for easy cleaning.

For compact power grinding, you can't beat the Hollymatic 190 Automatic Grinder. For more information contact Hollymatic or your local authorized Hollymatic dealer today!



Hollymatic®

YOUR PRICE VALUE LEADER™

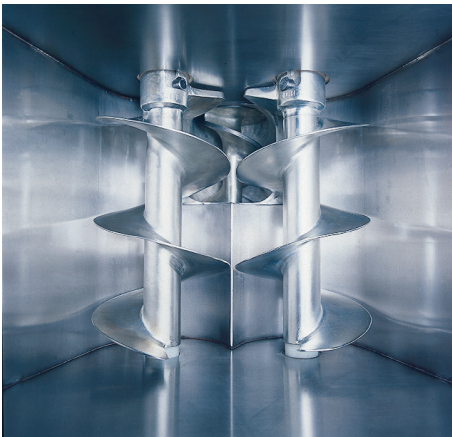
**SELF-FEEDING AUGERS**

These specially engineered high strength/high torque augers are the heart of the Hollymatic 190. The positive feed design moves tempered meat or large pieces of fresh meat completely through the grinder, making batch change and clean-up fast and easy.

**OPTIONAL TUB EXTENSION**

The 10" extension allows the grinder to be used without a lid, increasing capacity to 200 lbs., facilitating both conveyor feeding and manual loading.

WARNING: A minimum of 63" must be maintained between the working level and the top of the extension.

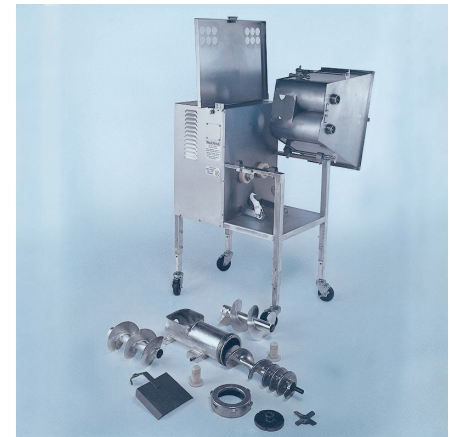
**EASY TO CLEAN**

The Hollymatic 190 is constructed of high quality, easy to clean materials. Its stainless steel, swing-open tub and no special tool disassembly make getting at the work areas easy for faster, safer, and more sanitary clean-up. The four, heavy duty swivel lock casters make it easy to move the 190 to a clean-up area.

SPECIFICATIONS**STANDARD FEATURES**

- 7-1/2 Hp motor
- #52 head
- Swing-open tub
- Start/stop controls (available right or left hand)
- Interlock switch shuts off the 190 when lid is opened or optional extension is raised
- Inspection holes in lid
- Meat deflector
- Standard adjustable legs
- Four, heavy duty swivel lock casters
- Weight/640 lbs.

AVAILABLE VOLTAGES

- 200 V., 3 Ph., 60 Hz., 25 A.
- 230/460 V., 3 Ph., 60 Hz., 22/11A.
- 575 V., 3 Ph., 60 Hz., 8.8A.
- 220/380 V., 3 Ph., 50 Hz., 24/14A.

FIRST GRIND PERFORMANCE

Production output: 3,200 to 6,500 lbs. per hour. Dependent on grinder plate size, reducer speed, and product.

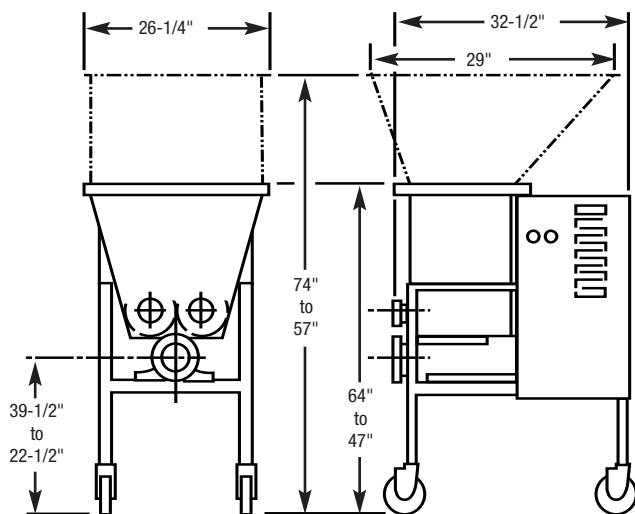
**OPTIONAL FEATURES**

- Hopper extension
- Interlocked lid for hopper extension
- High elevation adjustable legs
- Feed screw speed: 120 RPM (15:1)
180 RPM (10:1)

HOLLYMATIC WARRANTY

Six (6) months from date of purchase.
Refer to warranty certificate for terms and conditions

Hollymatic Corporation,

600 E. Plainfield Road, Countryside, Illinois 60525
708/579-3700 Fax: 708/579-1057
Web Site: www.hollymatic.com

**Hollymatic®**

YOUR PRICE VALUE LEADER™