

# Southern PRIDE

## SPECIFICATIONS MODEL SC-200-SM



### COOKING CAPACITIES FOR THE SC-200

Pork Butt (7 lb.)	30 pieces	210 lb. total
St. Louis Ribs (2.75 lb.)	25 pieces	69 lb. total
w/Optional Rib Racks	65 pieces	179 lb. total
Chicken (3 lb.)	40 pieces	120 lb. total
Brisket (12 lb.)	15 pieces	180 lb. total
Spare Ribs (3.5 lb.)	20 pieces	70 lb. total

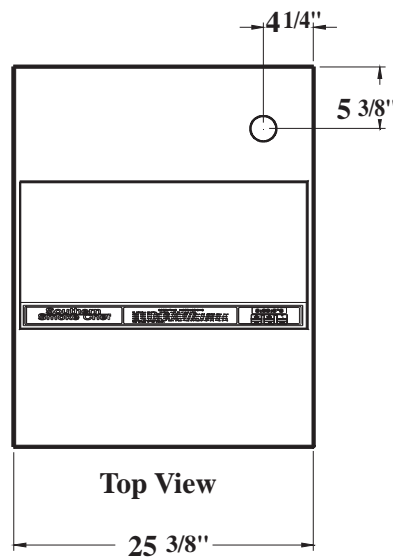
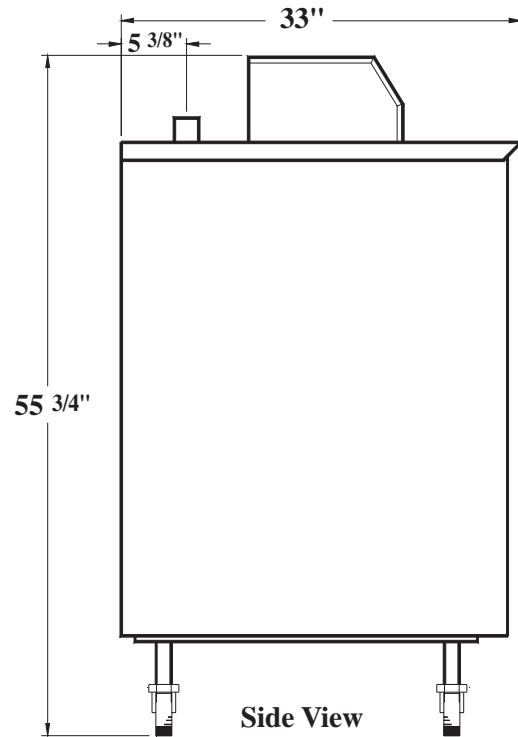
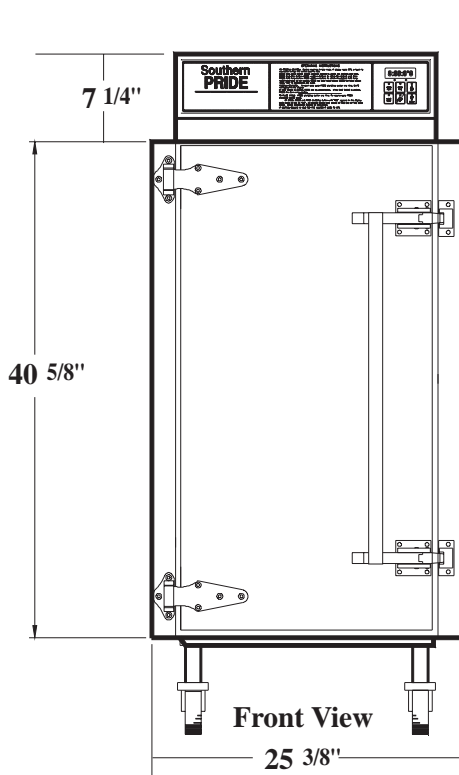

### SC-200-SM

**Electrical Requirements:** 120/208 or 120/240 volts AC, 60 hertz, 1 phase, 30 amp, 4 wire connection.

**Control:** Digital Roast and Hold

**Construction:** 18 ga. Stainless Steel Liner, 22 ga. Stainless Steel Exterior.

**Chipbox:** Uses any wood chips or charcoal.

**Dimensions:** 55 3/4" tall, 25 3/8" wide, 33" deep

**Shell Dimensions:** 40 5/8" tall, 25 3/8" wide, 33" deep.

**Food Racks:** Five food racks 18" x 26"  
16.25 Sq.Ft. of Cooking Surface. 5" Rack Spacing.

**Air Circulation:** Low Velocity Convection Fan.

**Temperature Range:** 140-325 degrees F.

**Shipping Weight:** 375 lbs.

**Approvals:** UL, ULC, NSF



**Venting:** Must be installed under a vent hood.

Contact local code officials and a commercial kitchen ventilation contractor prior to installation.

# Southern PRIDE

Southern Pride Distributing, L.L.C.

5003 Meadowland Pky - Marion, Illinois 62959-5892

www.southern-pride.com sales@sopride.com service@sopride.com parts@sopride.com

Sales: 800-851-8180

Service: 800-437-2679

Service Fax: 618-993-0378

Phone: 618-997-9348

Fax: 618-993-5960